

Büyük Kapasiteli off grid sistemler

Büyük Kapasiteli off grid sistemler

Maksimum sistem boyutu 180kVA'dır.

Daha da büyük sistemler için devreleri ayırın ve çoklu bireysel sistemler

- Büyük sistemlerin karmaşıklığını hafife almayın!
- Bu büyük boyutlu sistemlerde çalışan eğitimsiz ve/veya deneyimsiz kurulumcuları desteklemiyoruz
- Tasarım ve devreye alma için deneyimli bir montajcı tutmayı düşünün. Satış yöneticinizle iletişime geçin.

Tecrübe kazan:

- ✓ Paralel, tek fazlı sistem 10 ila 30 kVA ile başlayın
- ✓ Daha sonra tek ünite, 3 fazlı sistem 30 kVA
- ✓ Daha sonra çok üniteli, 3 fazlı bir sistem 60 kVA



3 Faz sistem

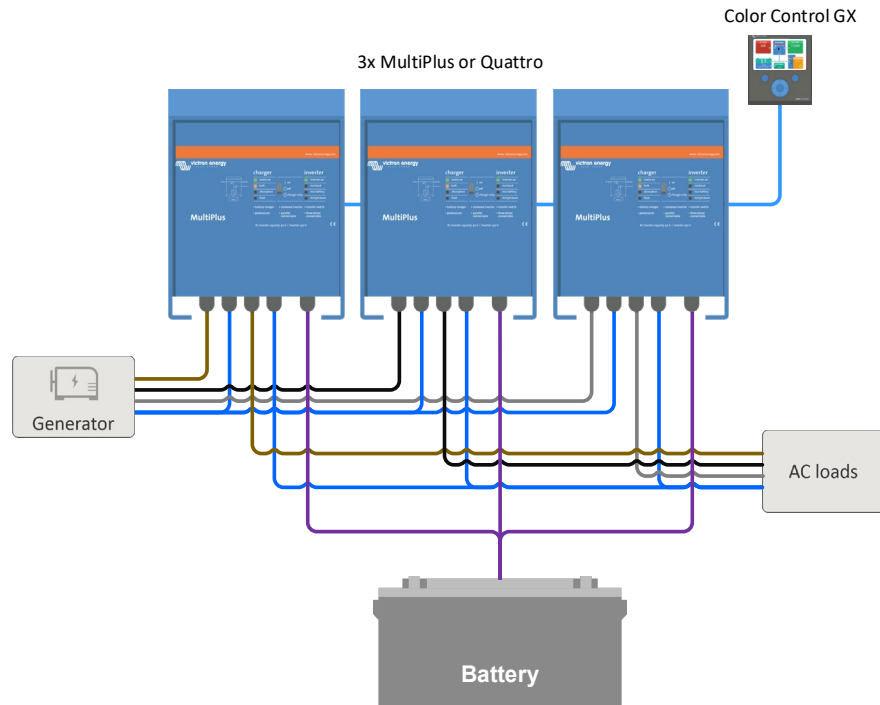

AC güneş enerjisi ile 3 fazlı sistem

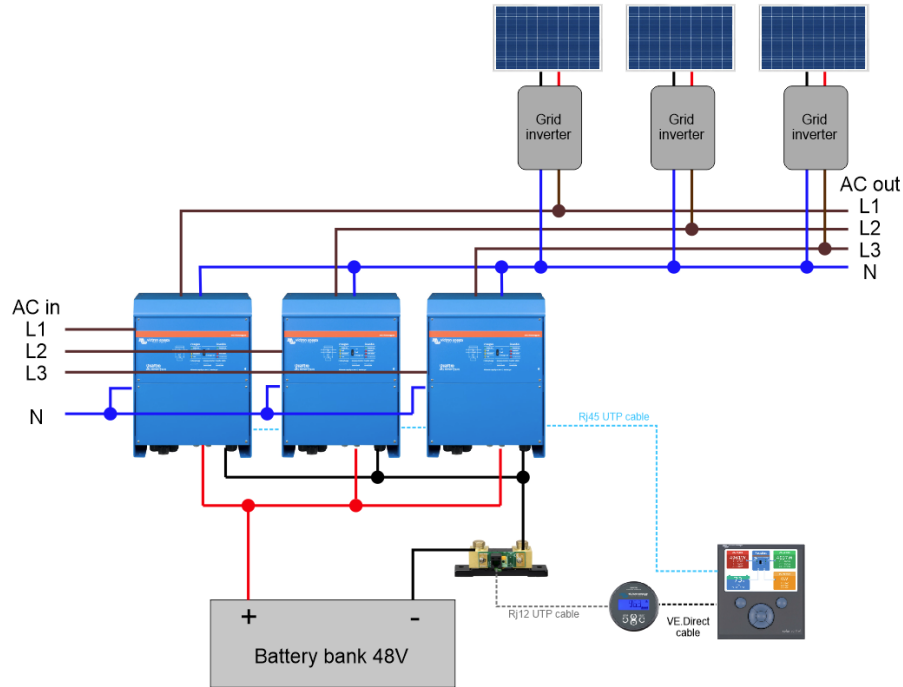

DC güneş enerjisi ile 3 fazlı sistem

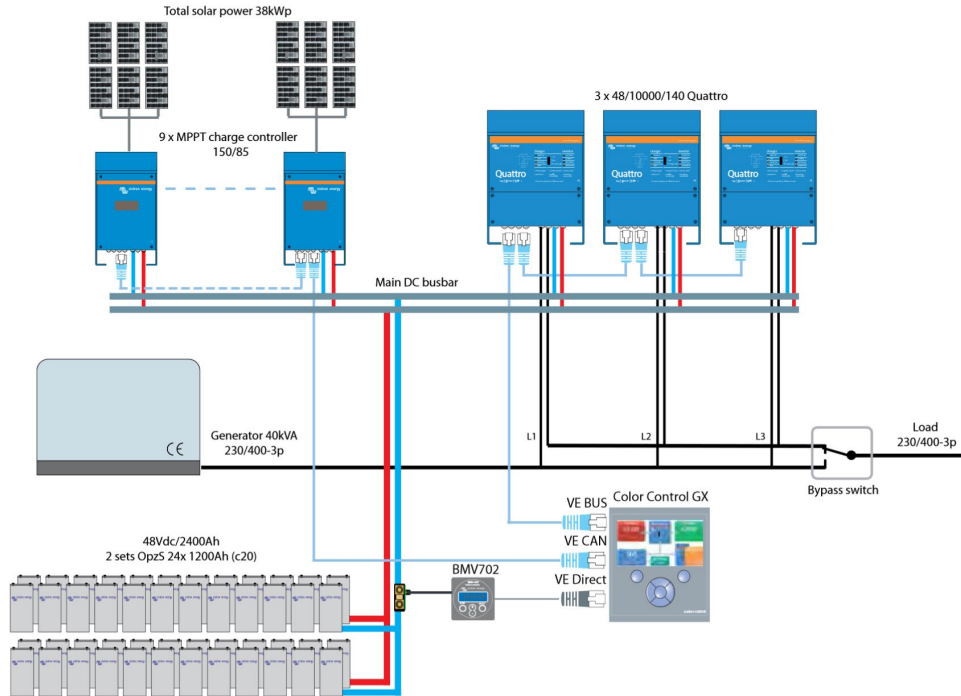

Parallel System

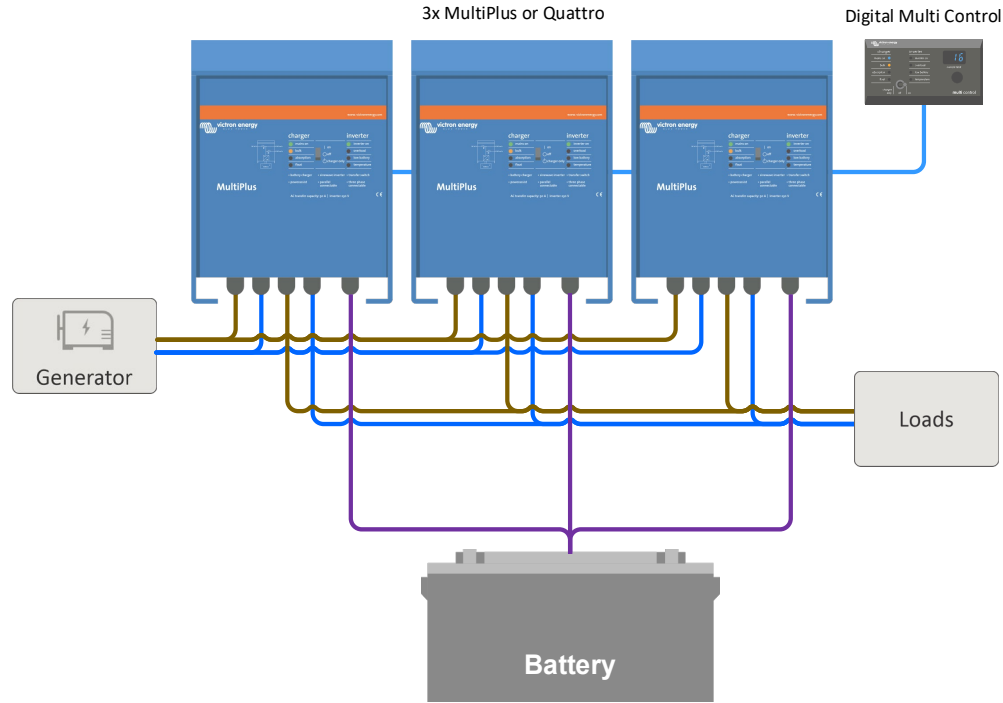

Faz başına paralel sistemler

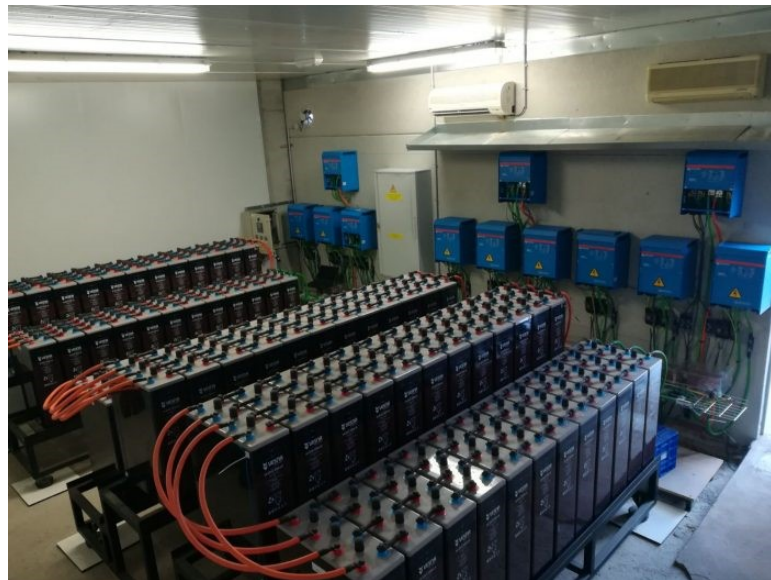
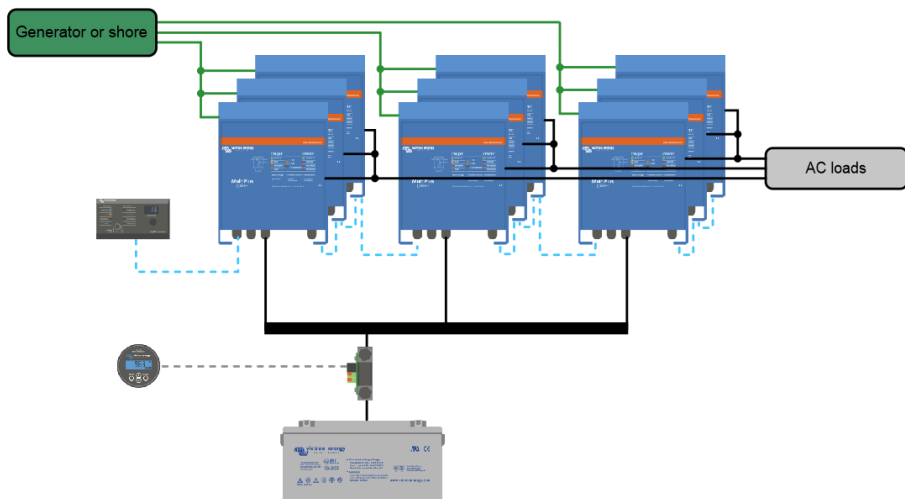

Mini and micro grids

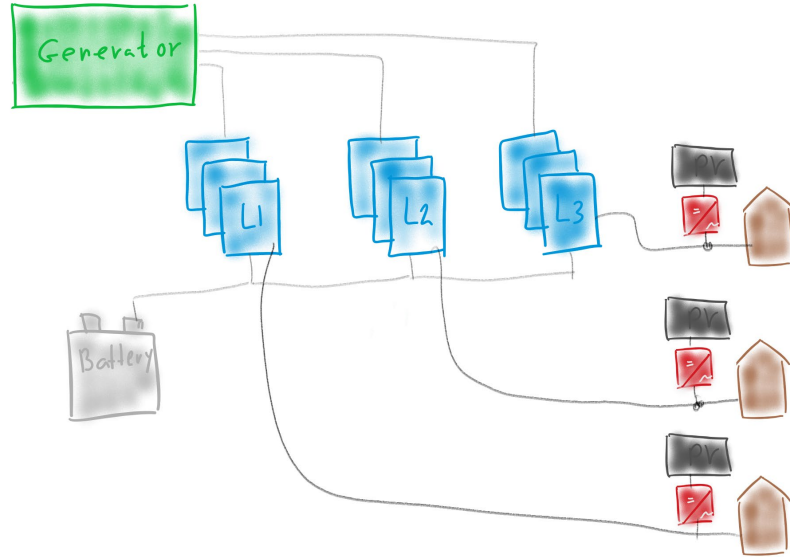

Yönetilen pillere sahip sistemler

Yönetilen pillere sahip sistemler

- BYD
- Pylontech
- and many more

- Bu piller, bir şarj durumu parametresi oluşturur ve bunu diğer iletişim araçlarının yanı sıra bir GX cihazına gönderir.



BYD battery

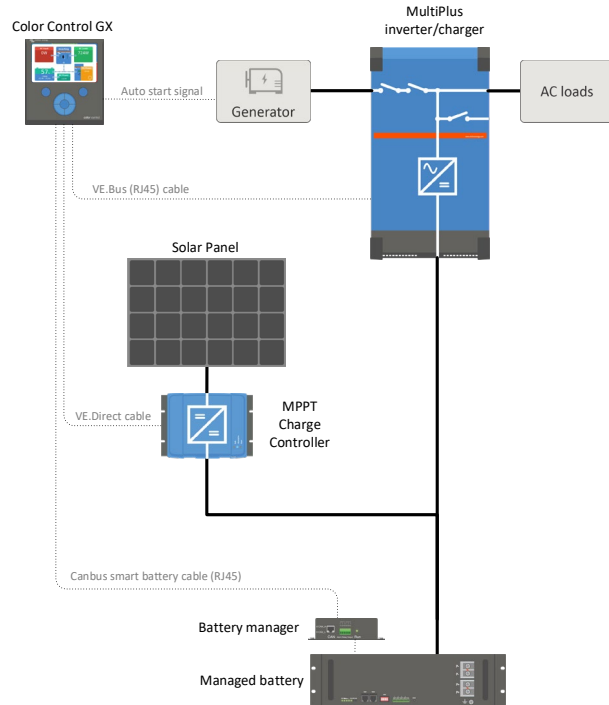

Pylontech

